

IMPORTANT SAFETY INFORMATION • DO NOT DISCARD

OPERATION MANUAL HYDRO INNOVATIONS™

Functions and Features:

- Adjustable CO2 output from 15 – 45 cubic feet per hour.
- Water-cooled design removes 86% of the heat produced.
- Adjustable water flow valve.
- High / low gas setting.
- Compact, wall-mount or suspended design.
- Water activates the unit.
- No flow / no go switch cuts off flame if water flow stops.
- Auto-cut off protection for gas leaks and tipping over.
- Overheat shutdown sensor.
- Oxygen depletion sensor
- Over pressure protection.
- All copper water passages.
- Inline water debris screen.
- 1 year warranty with great service.
- Optional valve for hooking unit directly to pressurized municipal water supply.



FREE
instructional videos
are available online at:
youtube.com

OPERATION MANUAL

IMPORTANT SAFETY INFORMATION • DO NOT DISCARD

 **HydroGEN™**

WATER-COOLED CO₂ GENERATOR

 **HydroGEN™**

WATER-COOLED CO₂ GENERATOR

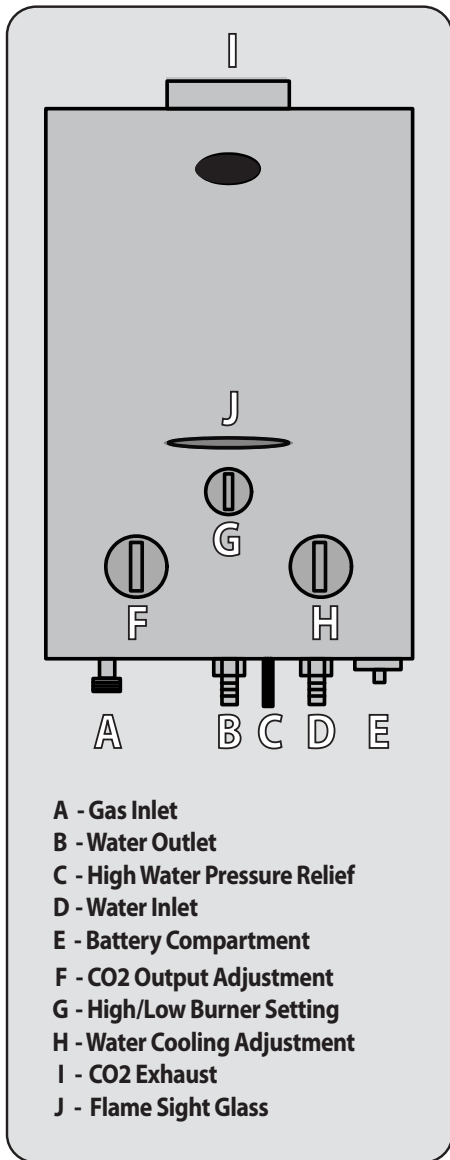

HydroGEN Packing List:

- 1 • HydroGEN Unit
- 2 • (1) 12' Propane Hose
- 3 • Propane regulator
- 4 • (2) ½" Hose Barb Adapters
- 5 • (2) Rubber Gaskets
- 6 • (2) 'D' Size Batteries
- 7 • (1) Gas Adapter Fitting
- 8 • (1) Warranty Card



• (1) Gas Adapter Fitting



• (1) Warranty Card



• HydroGEN Unit

• (2) ½" Hose Barb Adapters



• (2) Rubber Gaskets



• (1) 12' Propane Hose



• (2) 'D' Size Batteries

Installation Instructions

Hanging Method: The HydroGEN can be suspended from the ceiling using chains and "S" hooks. First securely fasten two chains 14" apart to a rafter, brace, beam, etc (not just into the sheetrock). Keep in mind that there is a flame inside and when we say securely fasten we mean it. Notice there are ¼" holes at the top center of the sides. These holes are there to allow for installations of "S" hooks that can then be attached to the chains at least 2' from the ceiling or any other obstruction.

Wall Mount Method: The HydroGEN can be screwed into a wall brace, stud, or beam using the brackets located at the top and bottom of the unit. Remember 2' from the top of the HydroGEN to the ceiling or any other obstruction.

Ducting CO2: When mounting the unit inside the grow room, no ducting is required. If you choose to mount your HydroGEN outside your grow room, a 3" double-wall ducting from your local hardware store is recommended. Note that this is NOT aluminum dryer vent, it's double-walled, insulated steel of the same type used in hot water heater applications. The vent piping should travel at an upward pitch to ensure that CO2 will travel into the grow room. When installed at an upward pitch CO2 will travel up to 5 feet. We do not recommend using a booster fan as they can affect flame efficiency, but a very low cfm fan can be used if forced to duct CO2 further than 5 feet from the unit. DO NOT use a fan more powerful than 20 cfm. Also, when using the CO2 generator outside the grow room, we recommend mounting a carbon monoxide detector in the room with the generator. This can be purchased at your local discount store for about \$10. We recommend this because even though the majority of CO2 is being ducted into the grow room, some will still be released into the room in which the generator is housed, and gas levels should be monitored to ensure safety. The odds of CO levels rising to dangerous levels is very, very slim but it's much better to be safe than sorry.

Propane Hose: The propane hose should be in good condition free from cracks or kinks. The hoses fittings and regulator should also be in good condition and should not be used if any damage has occurred. Attach the supplied propane hose to the HydroGEN using a properly sized wrench WITH A BACKUP WRENCH on the unit itself. Make it snug, but don't break it. Over tightening can cause a gas leak. Attach the other end of the hose to a 20 lb propane bottle that is in good condition. Do not use propane bottle that has a damaged, old, or leaky valve. After installing open gas valve and check for leaks. Applying soapy water over the joints will tell you right away if there is a leak.

Attaching Water Hoses: Snugly screw both supplied hose barb adapters onto the water inlet and outlet. MAKE SURE THE RUBBER GASKET IS INSTALLED! Attach ½" ID HEAVY DUTY REINFORCED TUBING to the hose barbs and install hose clamps. Cold water inlet should be clearly marked along with the hot water outlet.

Installing Batteries: The battery compartment is grey and is located on the bottom of the HydroGEN. The unit is supplied with two "D" size batteries and they must be installed properly. The + and - are marked on the inside of the battery compartment.

Starting Unit: The HydroGEN's burner is activated by 1.5 gpm of water flow and also requires at least 3 P.S.I. of pressure to operate. You must either connect the unit to a submersible or inline pump with at least 15' of lift that is powered on by the CO2 monitor, or the unit can be hooked directly to a pressurized water source like a municipal water supply. In this manner an on/off valve can be controlled by the CO2 monitor. For more water supply ideas go to www.hydroinnovations.com. If your water supply is ready it's time to fire it up. Turn on the water supply to the HydroGEN and you should hear clicks which is the automatic ignition lighting the burner. If the unit does not light right away this is most likely caused by air in the propane hose. Turn off the water supply and then on again, this is normal and it may take several attempts to remove all the air from a new unit.

Acceptable Water Sources: Clean water of course, used nutrient water, RO waste water, well water, municipal water supply, swimming pool or hot tub, collected rain water, etc. You can store your old nutrient water and/or RO waste and run it through the unit prior to discarding down the drain. If using sources other than tap, we recommend using a simple sediment filter of some kind that can be located at any hardware store. There is also a protective screen at the water intake on the unit to keep large debris from running through the unit. We recommend checking and/or cleaning this intake screen and your water filter (if using) at least monthly to ensure continued adequate water flow. If water flow diminishes, a dirty filter or clogged screen is the most likely culprit.

Acceptable reservoirs: In-ground pools, above-ground pools, kiddie pools, bath tubs, hydroponics reservoirs, hot tub/jacuzzi, barrels, trash cans, or any other water-tight container. An above-ground pool, which can be purchased at your local discount store for less than \$100, functions as a great reservoir when placed outside. Night air is also a very effective cooling method.

Adjusting CO2 output and water flow valve: There are two knobs that ultimately control the CO2 output. At the lowest setting for both knobs the unit generates 15 cubic feet of CO2 an hour and 45 cu/ft/hr at the highest settings for both knobs. For more cooling turn the water flow up and when less is needed, in the winter for example, you can turn the water flow down to retain some of the heat. The most efficient setting for removing the most heat is the minimum setting for the gas and the maximum output for the water.

The HydroGEN burns propane like other units but has a few added features, the main one being the heat exchanger mounted above the flame that is used to water-cool 86% of the heat produced. Cool water is pumped through the heat exchanger and back to a reservoir or is drained to waste. If using a reservoir you would either need a water chiller, heat exchanger or a large reservoir (all outside the grow room) to remove the heat from the water.

Cooling Methods

These are only cooling suggestions. There are actually several ways to setup your cooling system.

WATER CHILLER COOLING METHOD

See Diagrams on Next Page ->

The least economical cooling method is using a chiller with a small reservoir. While the chiller does use a lot of energy, it's still significantly less energy than trying to air condition the heat produced by a standard CO2 generator. Further, it's very convenient because you can use a reservoir as small as 5 gallons in some cases. Below are two different methods for using a chiller, inline and closed loop.

Inline:

The most efficient way to use this method is to attach the chiller cold water outlet to the cold water inlet of the HydroGEN so that the coldest water possible is entering the unit. Since chillers are designed to run under constant water flow and water should only be flowing through the HydroGEN while it's running, two pumps will be required. First install a SMALL submersible pump plugged in to constant power and second install a more powerful inline pump plugged in to the CO2 monitor. Since the HydroGEN requires a pump with 15' of lift a smaller submersible pump will not activate the unit, allowing the needed constant water flow through the chiller. When the CO2 monitor activates the second inline pump this creates the pressure needed to activate the HydroGEN.

Closed Loop :

Install a secondary submersible pump in your reservoir, to circulate stored water through the chiller and directly back into the reservoir. This allows for the constant water flow needed to operate the chiller. You will need a separate pump, plugged into your CO2 monitor, to operate the HydroGEN.

• IMPORTANT NOTE •

CHILLERS REQUIRE CONSTANT WATER FLOW.

IF USING A CHILLER INLINE WITH YOUR HYDROGEN, BE SURE TO READ THE "WATER CHILLER COOLING METHOD" TO PROPERLY SETUP YOUR SYSTEM.

TIP

Whatever cooling method you choose be SURE that anything that is warmer than your desired room temperature is mounted outside your growing environment. These things include water chillers, hot reservoirs and heat exchangers. If these items are inside your environment there is no heat exchange happening. Just remember the heat has to go somewhere! A 55 gallon barrel of 100 degree water is basically a 55 gallon heater. Your reservoirs should be located inside your garden environment only if the water that they contain stays near or below room temperature.

Reservoir And Chiller Method

CO2 NEEDED PER HOUR	RESERVOIR SIZE	CHILLER SIZE
.1 to 1.5 cubic ft./hr.	20-40 Gallon	1/10th hp
1.5 to 4.5 cubic ft./hr.	40-70 Gallon	¼ hp chiller
4.5 to 9 cubic ft./hr.	70-100 Gallon	½ hp chiller
9 to 17 cubic ft./hr.	100-150 Gallon	1 hp chillers

WATER CHILLER COOLING METHOD

INLINE

The most efficient way to use this method is to attach the chiller cold water outlet to the cold water inlet of the HydroGEN so that the coldest water possible is entering the unit.

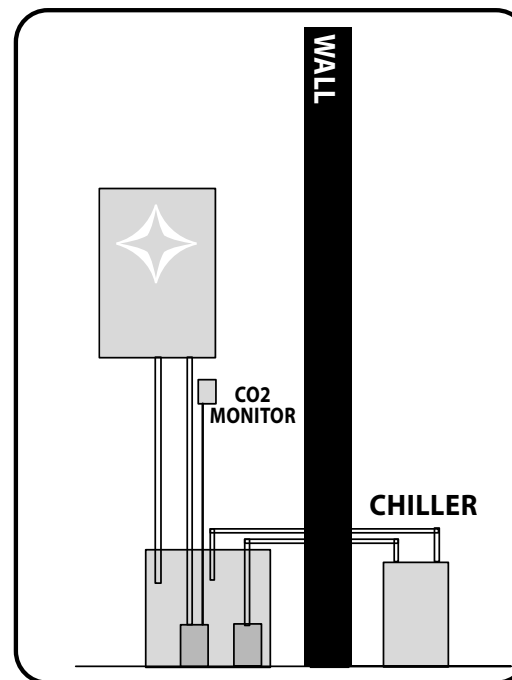
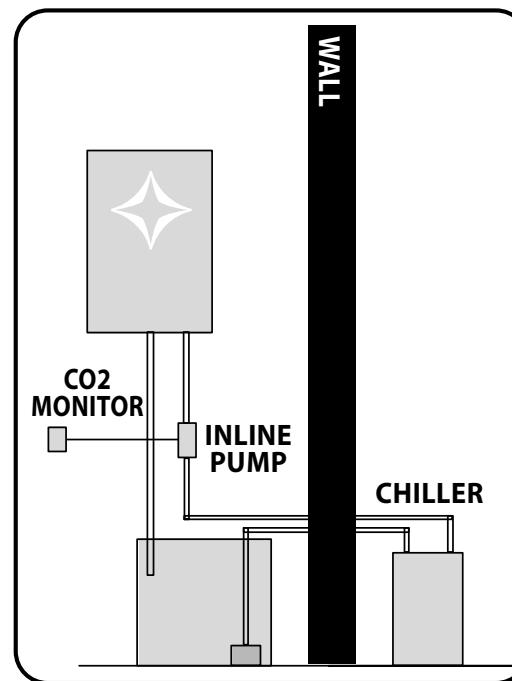

CLOSED LOOP

You will need a separate pump, plugged into your CO2 monitor, to operate the HydroGEN.

HEAT EXCHANGER COOLING METHOD

Heat Exchanger Cooling Method:

The third most efficient method is a small radiator with an attached fan. There are two different ways to do this, inline or closed loop.

Inline:

The heat exchanger can be used inline on the HOT water discharge hose. The hot water would pass through the heat exchanger which allows the fan to remove a majority of the heat before the water returns to the reservoir. The heat exchanger and fan must be mounted OUTSIDE the grow room and must be installed in the hot water discharge of the HydroGEN to be the most effective. This would be recommended for someone that uses the HydroGEN more than 30 minutes an hour since it is only cooling while water is flowing through the HydroGEN unit.

Closed Loop:

You can use a secondary submersible pump in your reservoir that's connected directly to the heat exchanger and exits back to your reservoir. Doing so this allows for constant cooling of the reservoir since the pump can be constantly running. You will need a separate pump, plugged into your co2 monitor, to operate the HydroGEN.

HEAT EXCHANGER COOLING METHOD

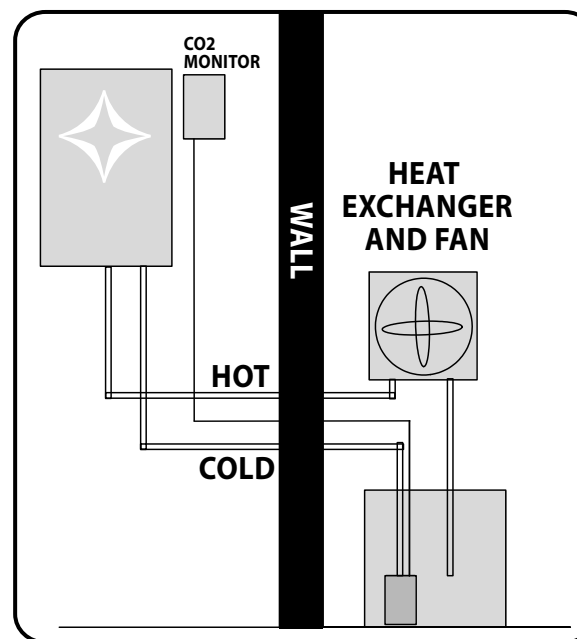

INLINE

The hot water would pass through the heat exchanger which allows the fan to remove a majority of the heat before the water returns to the reservoir.

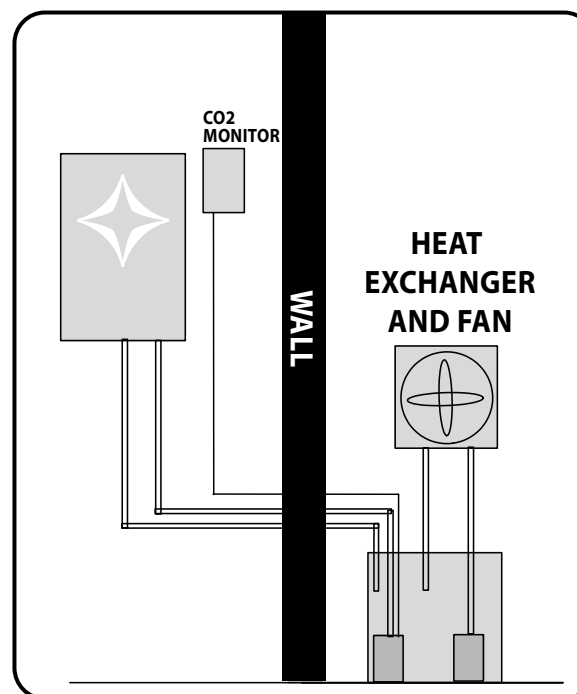

CLOSED LOOP



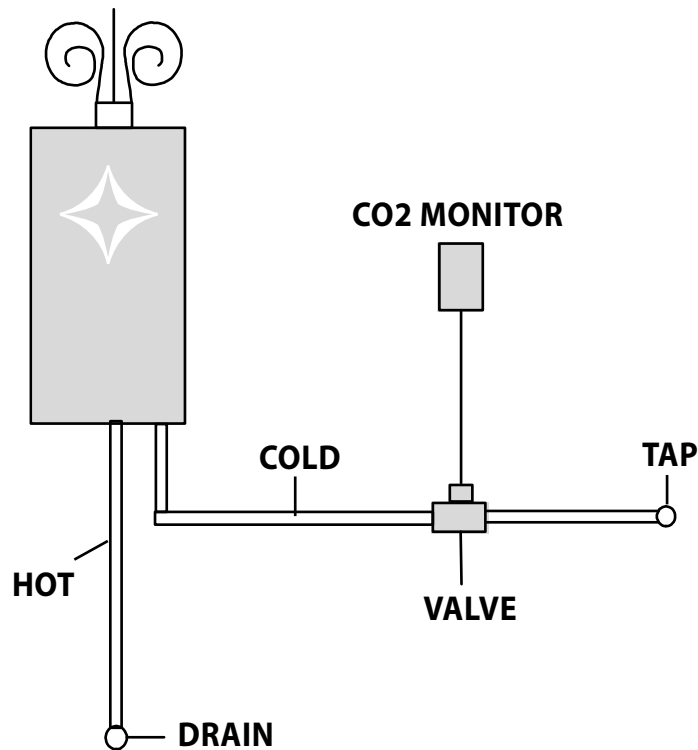

Doing so this allows for constant cooling of the reservoir since the pump can be constantly running.

DRAIN TO WASTE COOLING METHOD

The most economical way to cool the unit is drain to waste but is only recommended if using waste water to cool with. Store RO waste water, old nutrient water, and even rain water to use to cool the HydroGEN before disposing down the drain.



Drain To Waste / Storage / Reuse

	WATER USAGE	CO2 PRODUCTION
	13 Gallons / hour	1.5 cubic feet / hour
	26 Gallons / hour	3 cubic feet / hour
	38 Gallons / hour	4.5 cubic feet / hour
	75 Gallons / hour	9 cubic feet / hour

*At minimum water flow setting.

LARGE RESERVOIR COOLING METHOD

Another efficient cooling method is to circulate cool water from a large reservoir used outside your grow room. Barrels, plastic tubs, and even small above ground swimming pools can be bought for less than \$75 and make excellent reservoirs. During the off cycle the reservoir is allowed to naturally cool down, so obviously this idea works great for cooler areas.

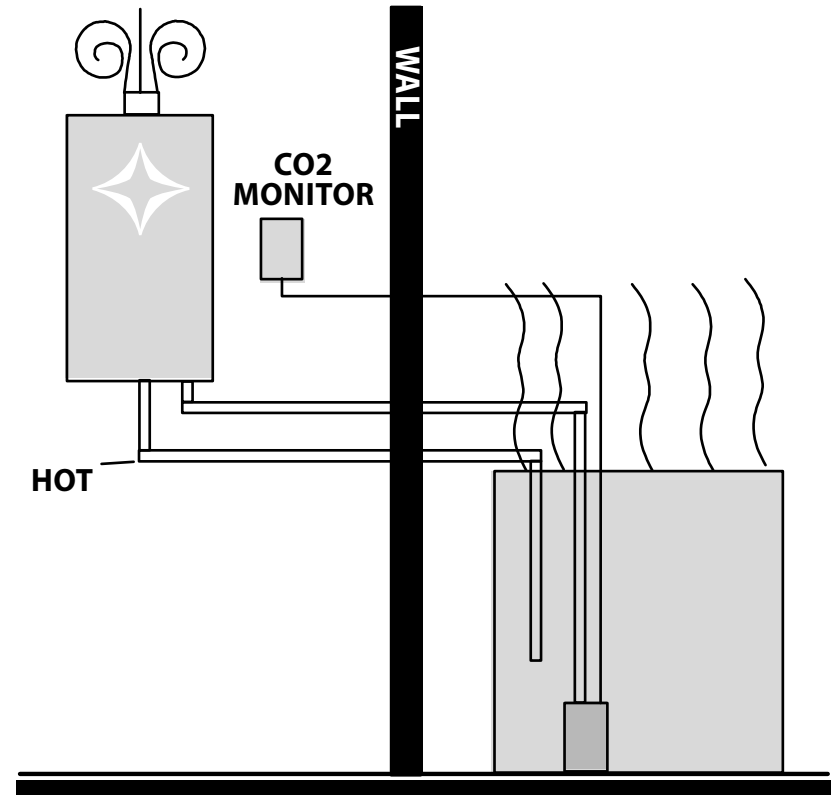

Reservoir No Chiller Method

CO2 NEEDED PER HOUR	SUGGESTED RESERVOIR SIZE
1.5 cubic feet / hour	100 Gallon
3 cubic feet / hour	200 Gallon
4.5 cubic feet / hour	300 Gallon
9 cubic feet / hour	600 Gallon

*For 12 hour CO2 cycle. Reservoir sizes are suggested only and can be larger or smaller depending on your application.

HUT DIAGRAM

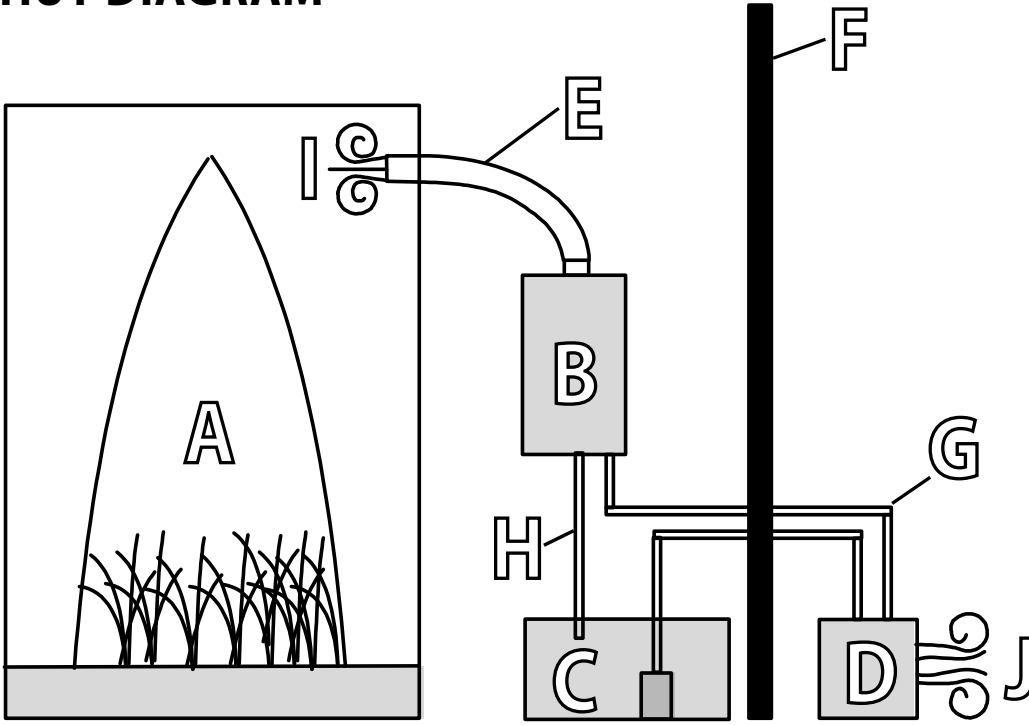

- A - Hut
- B - CO2 Generator
- C - Reservoir and Pump
- D - Chiller or Heat Exchanger
- E - CO2 Duct
- F - Wall
- G - Water Inlet
- H - Water Outlet
- I - CO2
- J - Heat

IN ROOM DIAGRAM

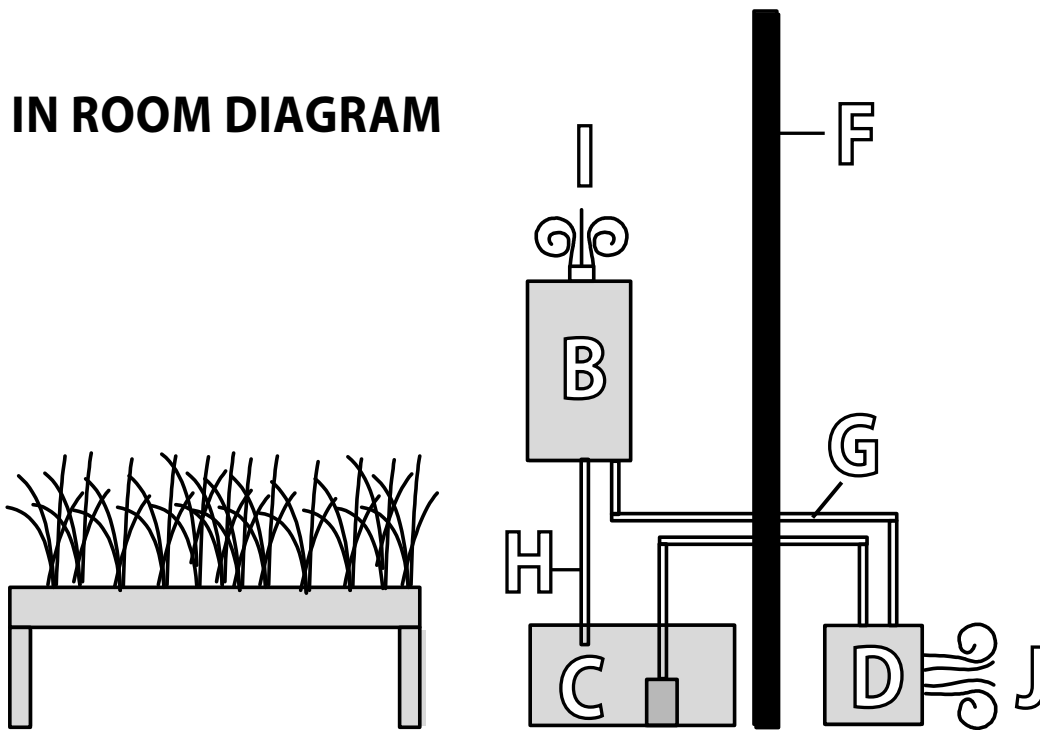

- A - Hut
- B - CO2 Generator
- C - Reservoir and Pump
- D - Chiller or Heat Exchanger
- E - CO2 Duct
- F - Wall
- G - Water Inlet
- H - Water Outlet
- I - CO2
- J - Heat

THROUGH WALL DIAGRAM

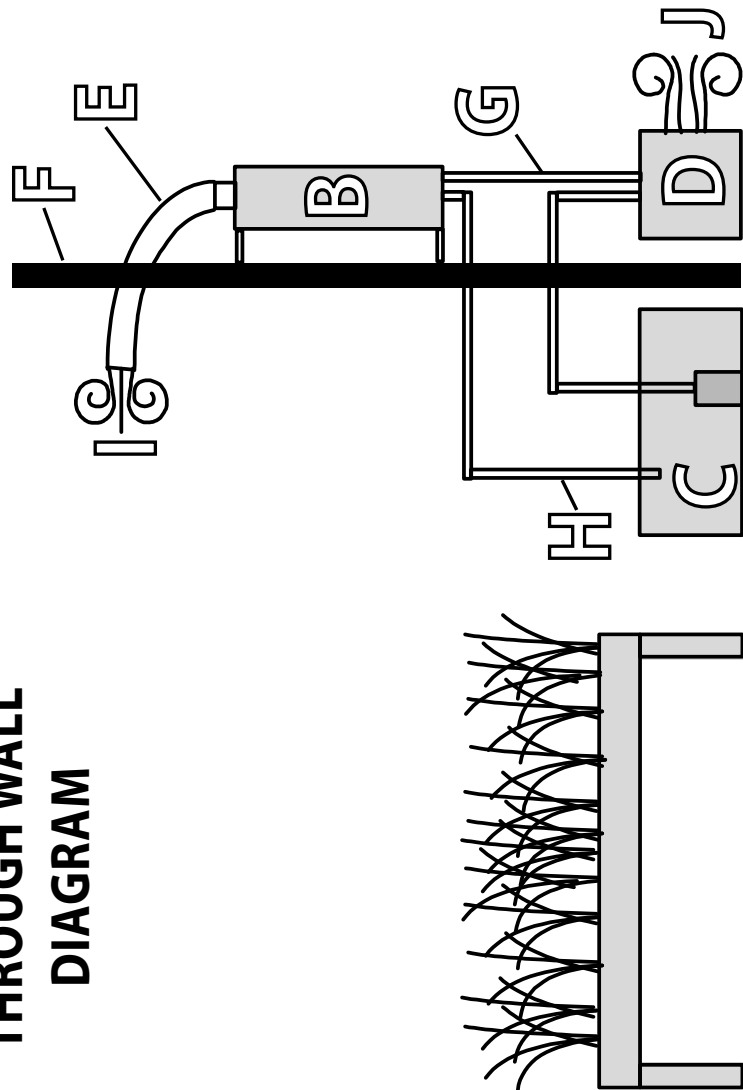

- A - Hut
- B - CO2 Generator
- C - Reservoir and Pump
- D - Chiller or Heat Exchanger
- E - CO2 Duct
- F - Wall
- G - Water Inlet
- H - Water Outlet
- I - CO2
- J - Heat

Troubleshooting:

Unit does not light!

- Check propane level (don't be fooled, bottles are heavy even when they are empty).
- Check propane valve and make sure it's on.
- Check the batteries and make sure they are installed properly.
- Replace batteries if it's possible they are discharged.
- Check for sufficient water flow/pressure.
(Water flow must be above 1.5 gpm and pressure has to be over 3 psi for the HydroGEN to operate. This is for safety reasons.)
- Check for clogged inlet screen causing low water flow.
- Overheat sensor could be activated. Let unit cool before trying to restart.
- Not enough oxygen for combustion-discontinue using until problem is solved.
- The HydroGEN will not operate if there is a gas leak.
Discontinue using until problem is solved.

! WARNING

PLEASE READ CAREFULLY

THE HYDROGEN MUST BE INSTALLED IN A WELL VENTILATED AREA JUST LIKE ANY OTHER DEVICE THAT BURNS PROPANE. OXYGEN MUST BE AVAILABLE FOR COMPLETE COMBUSTION OF THE PROPANE. WITH COMPLETE COMBUSTION OF PROPANE YOU GET GLORIOUS CO₂, WITH INCOMPLETE COMBUSTION YOU GET DEADLY CO (CARBON MONOXIDE). CO POISONING IS RESPONSIBLE FOR MANY DEATHS EVERY YEAR, SO BE SMART AND NEVER USE HYDROGEN IN A COMPLETELY SEALED ENVIRONMENT. A TIMED FRESH AIR INTAKE FAN WORKS GREAT FOR SUPPLYING OXYGEN FOR PLANTS AND FOR THE CO₂ GENERATOR.

- ! IF YOU SUSPECT A GAS LEAK TURN OFF PROPANE BOTTLE VALVE IMMEDIATELY. IF THE ROOM SMELLS LIKE GAS LEAVE IMMEDIATELY AND LEAVE A DOOR OR WINDOW OPEN FOR PROPANE GAS TO DISSIPATE. DO NOT PUT ANYTHING ON OR CLOSE TO THE UNIT, THIS COULD CAUSE SEVERAL FATAL PROBLEMS.
- ! KEEP A MINIMUM DISTANCE OF 2' AROUND THE HYDROGEN.
- ! LISTEN OCCASIONALLY FOR ABNORMAL COMBUSTION. IF YOU SUSPECT THIS, DISCONTINUE USE AND EITHER DIAGNOSE PROBLEM OR SEND THE UNIT BACK FOR REPAIR.
- ! DESPITE BEING WATER-COOLED THE OUTER HOUSING CAN GET VERY WARM. PLEASE AVOID TOUCHING THE HOUSING DURING OPERATION. THE KNOBS SHOULD BE OK TO TOUCH.
- ! DO NOT ALLOW UNIT OR HOSES TO FALL INTO DISREPAIR. CHECK BURNER, IGNITER, AND HEAT EXCHANGER FOR DUST PERIODICALLY. THIS DUST WILL HAMPER THE HYDROGEN'S PERFORMANCE.
- ! DO NOT USE THE HYDROGEN IN OUTDOOR CONDITIONS.
- ! ONLY USE PROPANE (LPG) FOR THE HYDROGEN UNLESS OTHERWISE SPECIFIED OR IT COULD KILL YOU.
- ! THE HYDROGEN MUST BE MOUNTED AT LEAST 2' FROM THE CEILING OR ENCLOSURE THAT IT'S MOUNTED IN TO ALLOW FOR LEFTOVER HEAT TO ESCAPE PROPERLY.
- ! KEEP THE PROPANE TANK AS FAR FROM THE UNIT AS POSSIBLE (THIS IS WHY YOU WERE SUPPLIED A 12' HOSE).
- ! WATER FLOW MUST EXCEED 1.5 GPM AND 3 PSI FOR THE HYDROGEN TO OPERATE.
- ! DON'T USE AGING OR CRACKING HOSES.

